

IN8303

ULTI Rack+

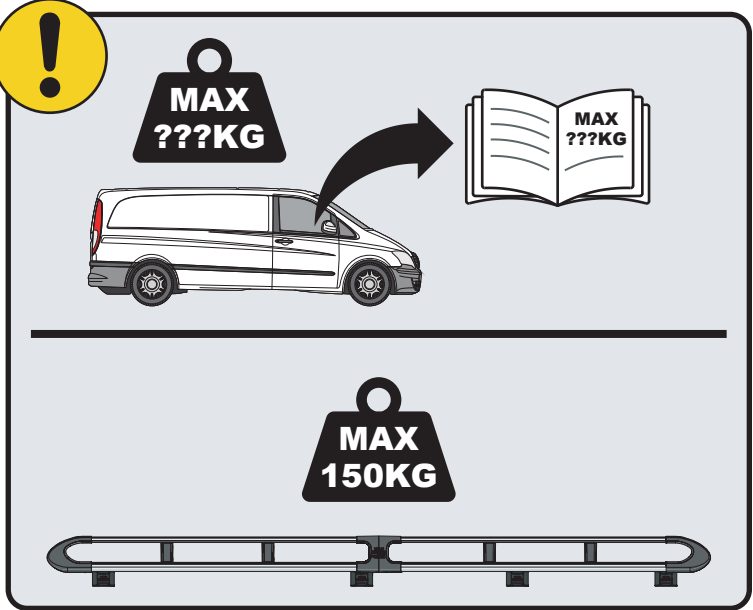

 Customercare@van-guard.co.uk
UK +44 (0) 1392 368 351

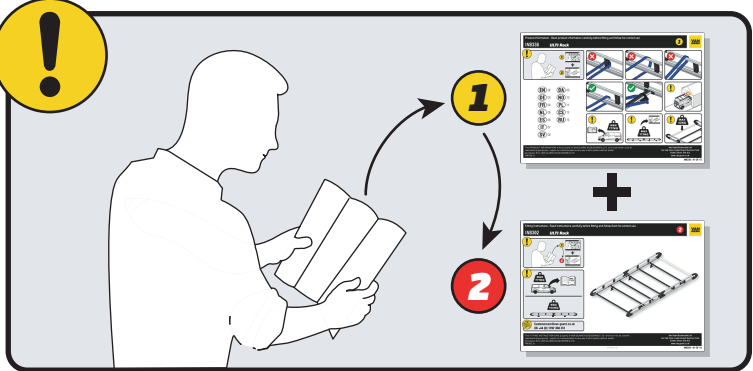

This FITTING INSTRUCTION is the property of VAN GUARD ACCESSORIES LTD. and must not be used for manufacturing purposes, copied nor communicated in any way to third parties without written permission from VAN GUARD ACCESSORIES LTD.
IN8303_B (CN:00356)

Van Guard Accessories Ltd
Fair Oak Close, Exeter Airport Business Park,
Exeter, Devon, EX5 2UL
www.van-guard.co.uk

VGUR-232

Mercedes Vito: 2003 on
L3H1
Tailgate

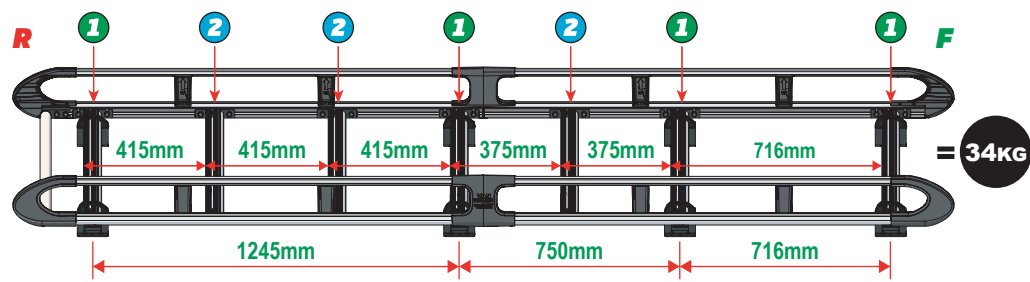
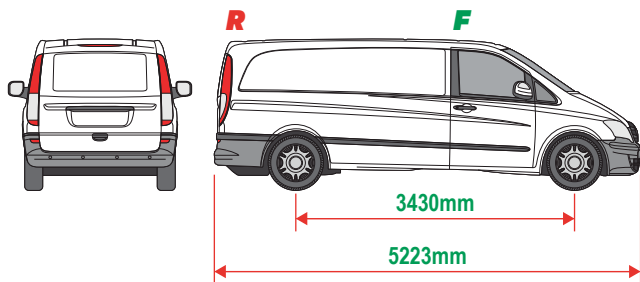

SUPPLIED COMPONENTS - CHECK ALL PARTS ARE PRESENT AND CORRECT BEFORE PROCEEDING (1 OF 2)

TOOLS REQUIRED

10MM X2

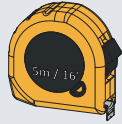

13MM X1

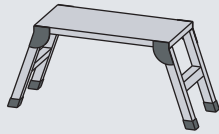
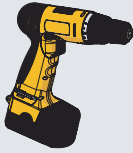

AS3541 X2
(3000 / A)

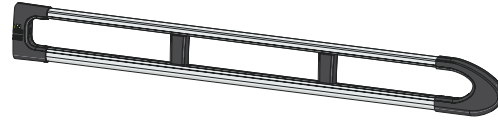

MA6118 X14



FX4241 X32

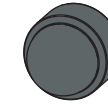

ME1622 X3

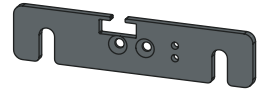

AS3540 X2
(3000 / B)

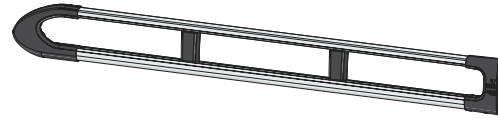

FX4008 X1



MA6145 X1

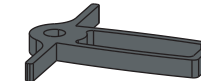

ME1623 X3

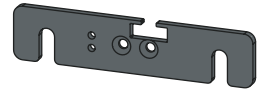

ME1627 X7
(1354mm)

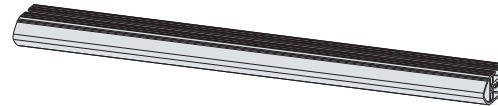

FX4001 X2
(M8X40)

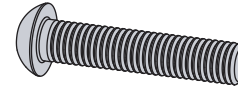

FX4235 X28
(M5X25)



ME0203 X8

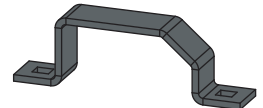

AS3159 X1
(1340mm)

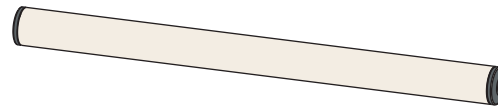

MA6007 X4

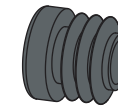

FX4248 X1
(T25)

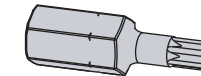

MA6065 X8

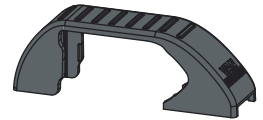

AS3590 X1

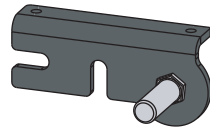

MA6093 X14

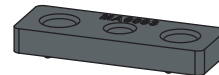

FX4239 X32
(M8X20)

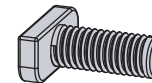

ME1620 X4

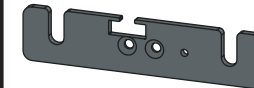

FX4016 X32
(M6)



AS3591 X1

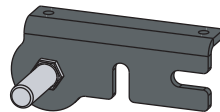

ME0316 X14

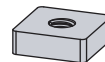

FX4240 X32
(M8)



ME1621 X4

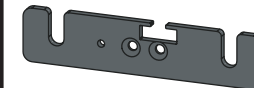

FX4042 X16
(M6X16)

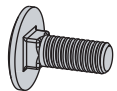

SUPPLIED COMPONENTS - CHECK ALL PARTS ARE PRESENT AND CORRECT BEFORE PROCEEDING (2 OF 2)

ME0729 X1

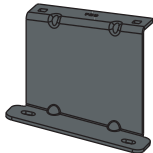

FX4013 X24

(M6)

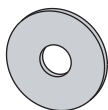

ME0730 X1

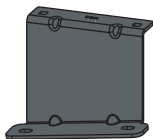

FX4014 X24



ME0731 X4

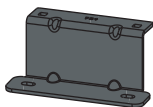

FX4021 X16

(M6X25)



ME0732 X1

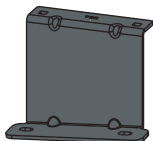

MA6019 X2



ME0733 X1

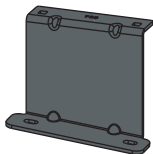

MA6020 X8



FX4012 X16

(M6X16)

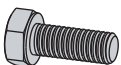

01

1L

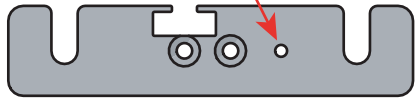

X4

1R

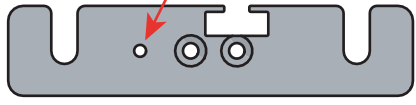

X4



2L



X3

2R

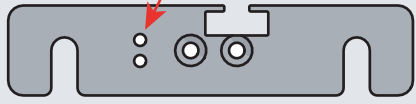

X3

02

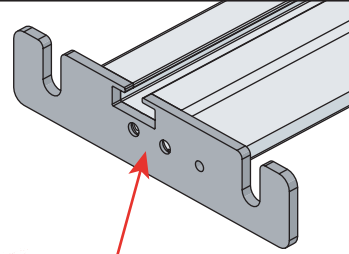
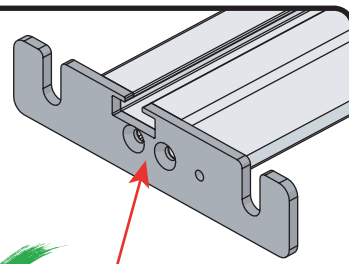

03

01

FX4248



+

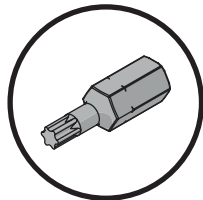

02

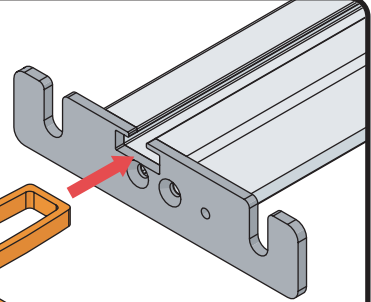
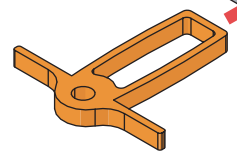

04

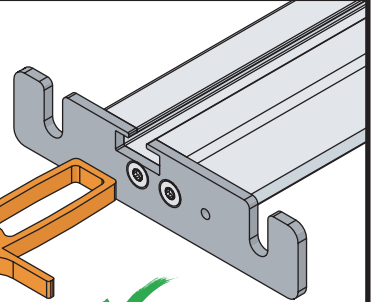
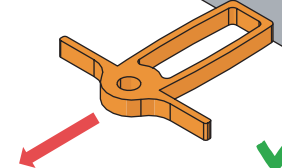

04



1

X4

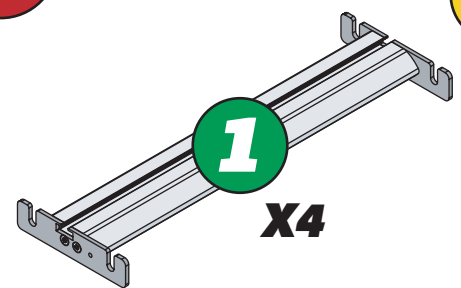

2

X3

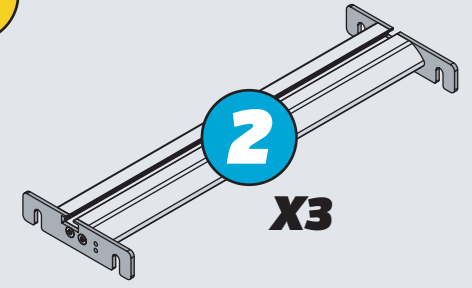

03



11Nm

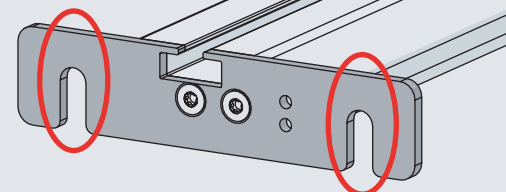
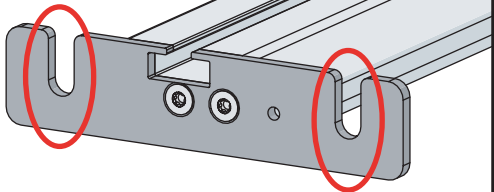
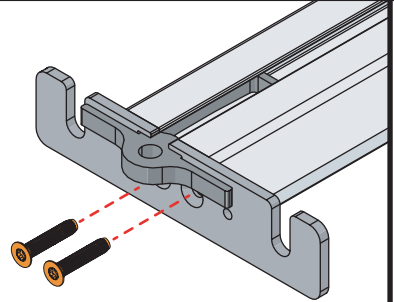

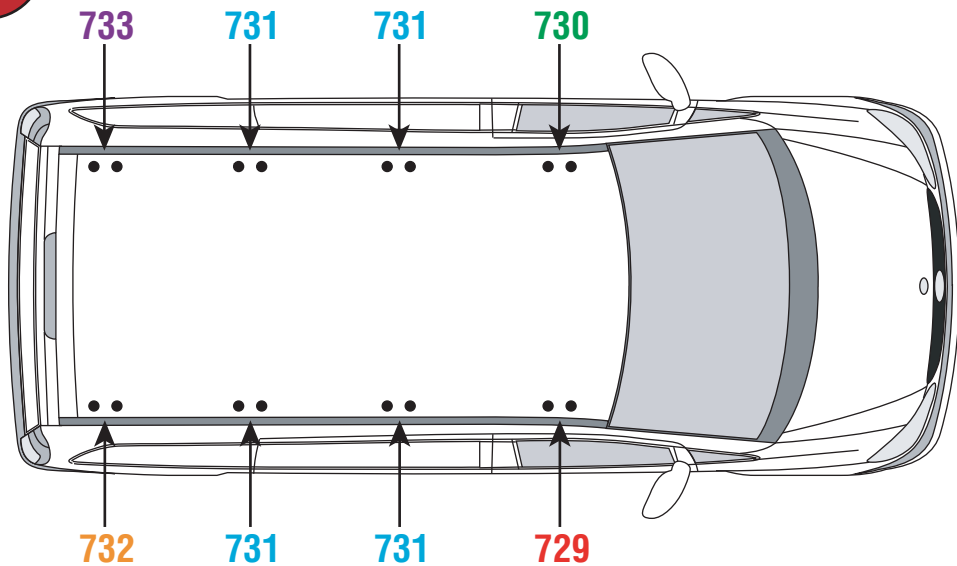
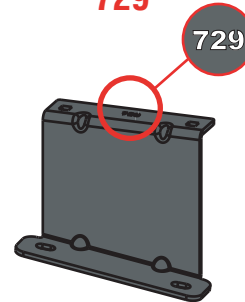
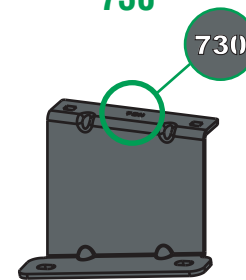
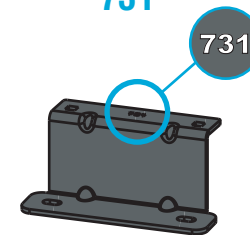
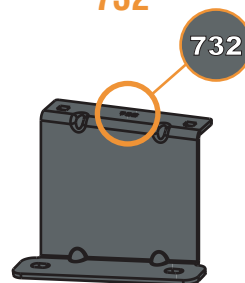
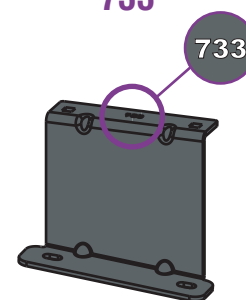
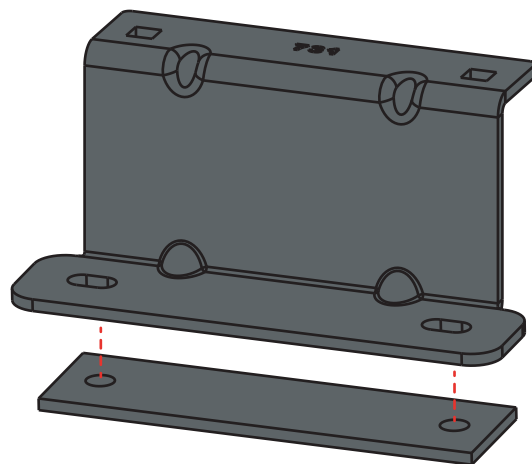
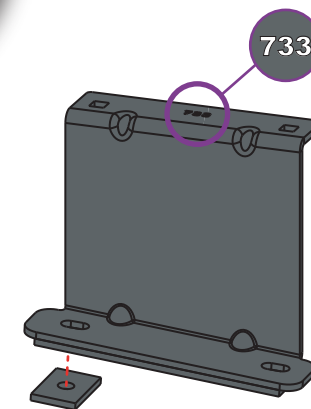
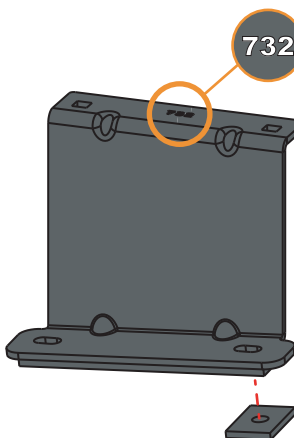
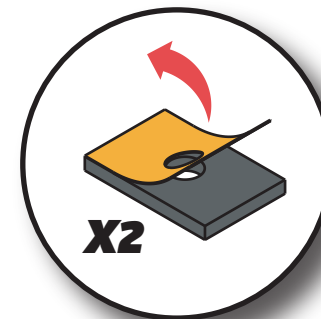
05**729****730****731****732****733****06****07**

EN - STICK GASKETS TO ALL BRACKETS
 DE - KLEBEN SIE DIE DICHTUNG AN ALLEN HALTERUNGEN
 FR - COUSSINETS ADHÉSIFS À TOUS LES SUPPORTS
 NL - PLAK PAKKING OP ALLE BEUGELS
 ES - PEGA LAS ALMOHADILLAS A TODOS LOS SOPORTES
 IT - ADESIVI GUARNIZIONI A TUTTE LE STAFFE

SV - FÄST GUMMI PÅ ALLA FÄSTEN
 DA - KLÆB GUMMI PÅ ALLE BESLAG
 NO - PLIST GUMMI PÅ ALLE BRAKKETER
 PL - NAKLEJ USZCZELKI DO WSZYSTKICH WSPORNIKÓW
 CS - PŘILEPTE TĚSNĚNÍ NA VŠECHNY DRŽÁKY

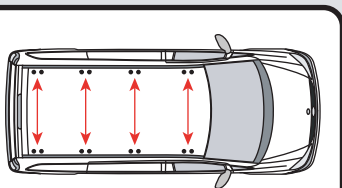
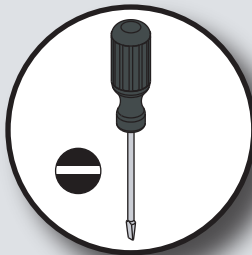
08**X16****09****A**
(10 & 11)**B**
(10 & 11)**C**
(10, 11 & 12)

15 - 20mm

25 - 30mm

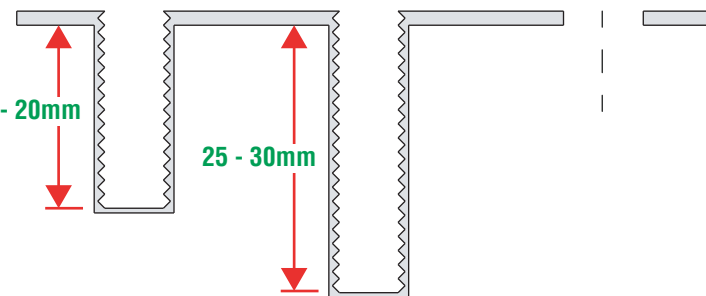

EN: CHECK THE VEHICLE FIXING POINTS AND FOLLOW THE RELEVANT STEPS
 DE: ÜBERPRÜFEN SIE DIE BEFESTIGUNGSPUNKTE UND BEFOLGEN SIE DIE RELEVANTEN SCHRITTE
 FR: VÉRIFIER LES POINTS DE FIXATION ET SUIVRE LES ÉTAPES PERTINENTES
 NL: CONTROLEER DE BEVESTIGINGSPUNTEN VAN HET VOERTUIG EN VOLG RELEVANTE STAPPEN
 ES: CONSULTE LOS PUNTOS DE FIJACIÓN DEL VEHÍCULO Y SIGA LOS PASOS CORRESPONDIENTES
 IT: CONTROLLARE I PUNTI DI FISSAGGIO DEL VEICOLO E SEGUIRE I PASSAGGI RELATIVI
 SV: KONTROLLERA FORDONS FASTPUNKT OCH FÖLJ RELEVANTA STEG
 DA: KONTROLLER KØRETØJETS FASTSÆTNINGSPUNKTER, OG FØLG RELEVANTE TRIN
 NO: KONTROLLER KJØRETØYETS FESTEPUNKTER OG FØLG RELEVANTE TRINN
 PL: SPRAWDŹ PUNKTY MOCOWANIA POJAZDU I WYKONAJ ODPOWIEDNIE KROKI
 CS: ZKONTROLUJTE UPEVNŔOVACÍ BODY VOZIDLA A DODRŔUJTE PŘÍSLUŠNÉ KROKY

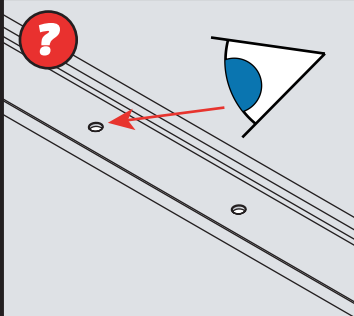
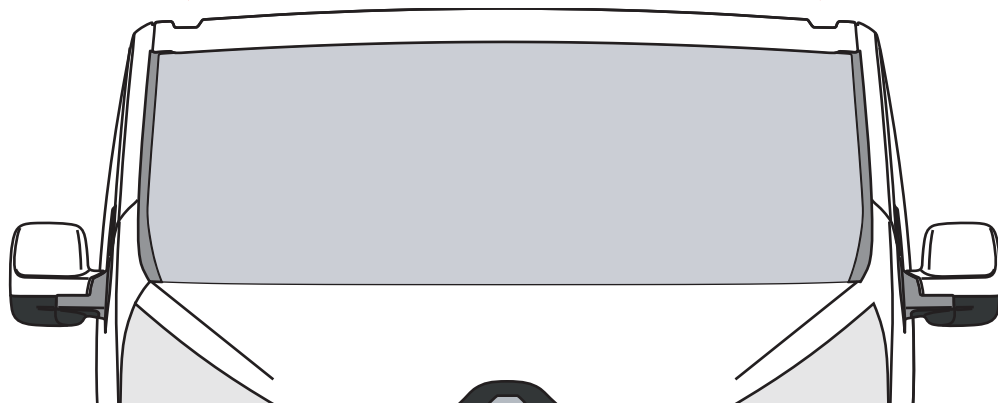
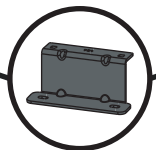
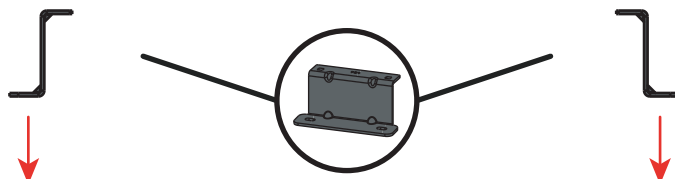
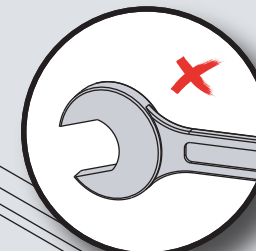
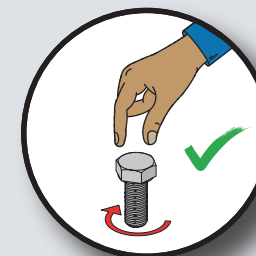
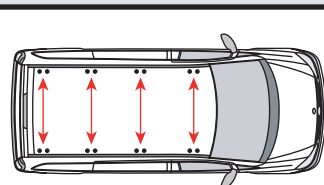
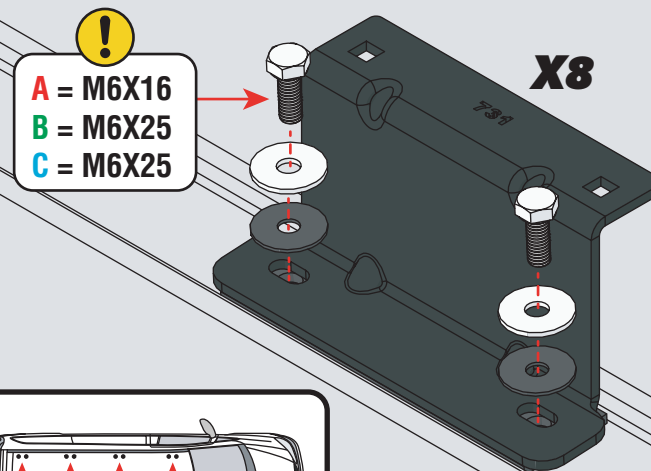
**10****A, B, C****11****A, B, C**

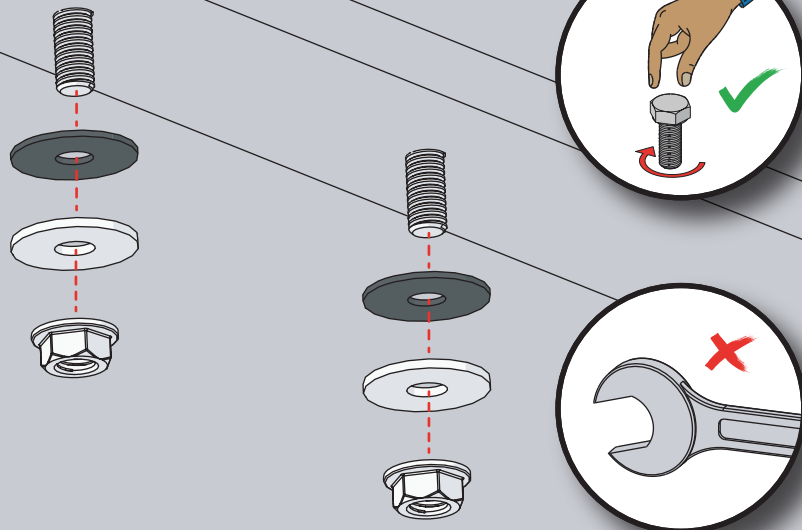
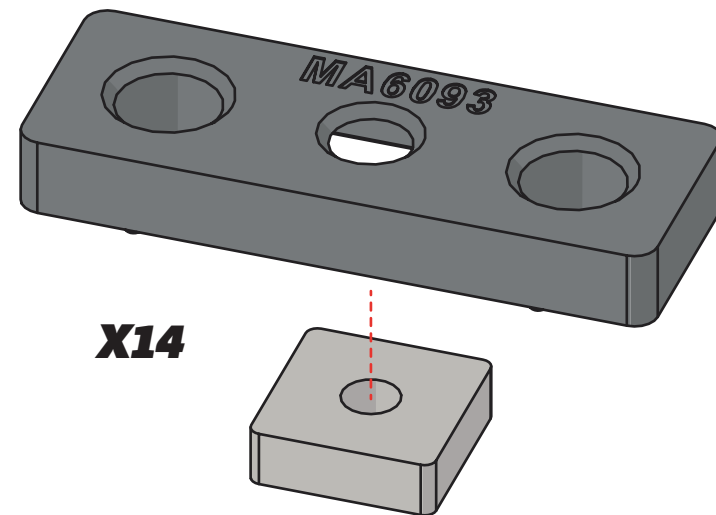
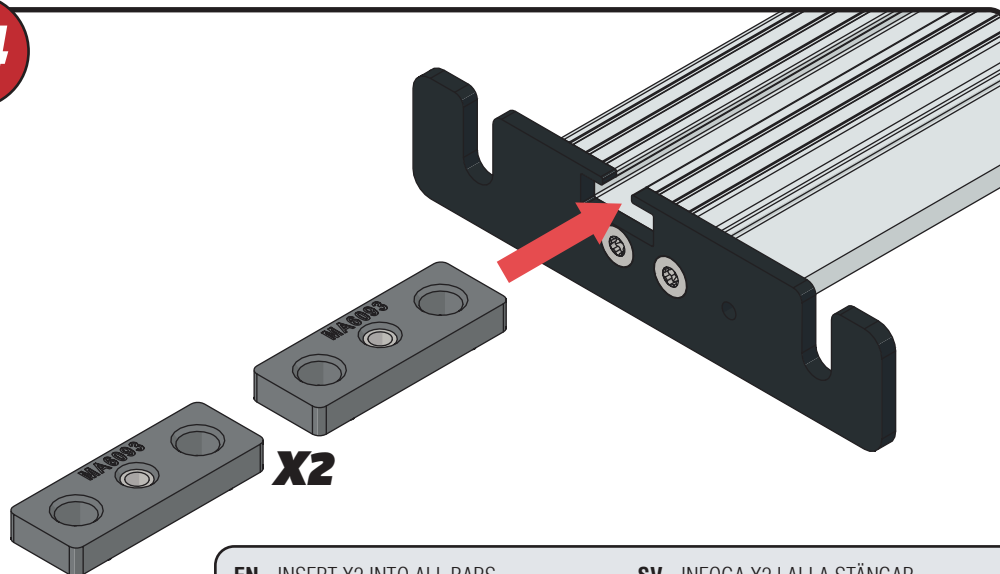
12**C****13****14**

EN - INSERT X2 INTO ALL BARS
 DE - X2 IN ALLE STANGEN EINFÜGEN
 FR - INSÉRER X2 DANS TOUTES LES BARRES
 NL - PLAATS X2 IN ALLE BARS
 ES - INSERTAR X2 EN TODAS LAS BARRAS
 IT - INSERIRE X2 IN TUTTE LE BARRE

SV - INFOGA X2 I ALLA STÄNGAR
 DA - INDSÆT X2 I ALLE STÆNGER
 NO - SETT X2 INN I ALLE TAKSTENGER
 PL - WSTAW X2 DO WSZYSTKICH PRĘTÓW
 CS - VLOŽTE X2 DO VŠECH TYČÍ
 RU - ВСТАВЬТЕ X2 ВО ВСЕ ПРУТКИ

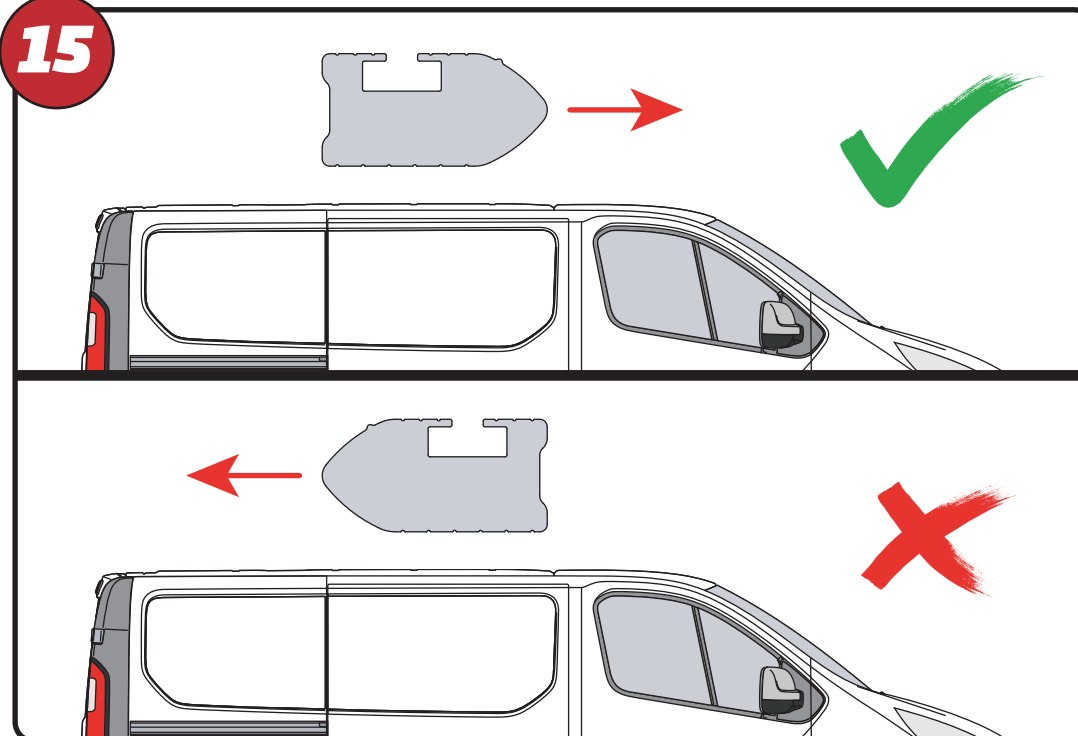
15

16

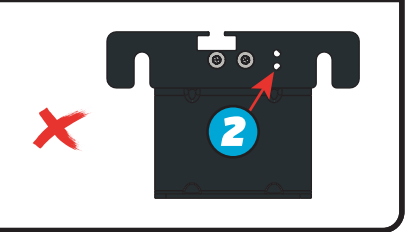
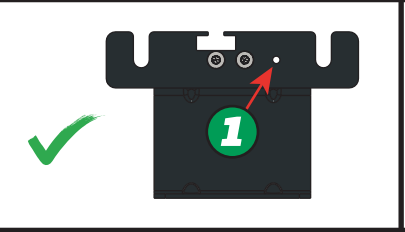
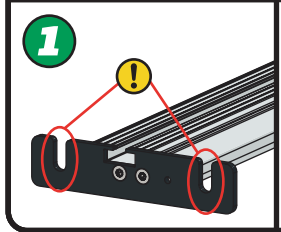
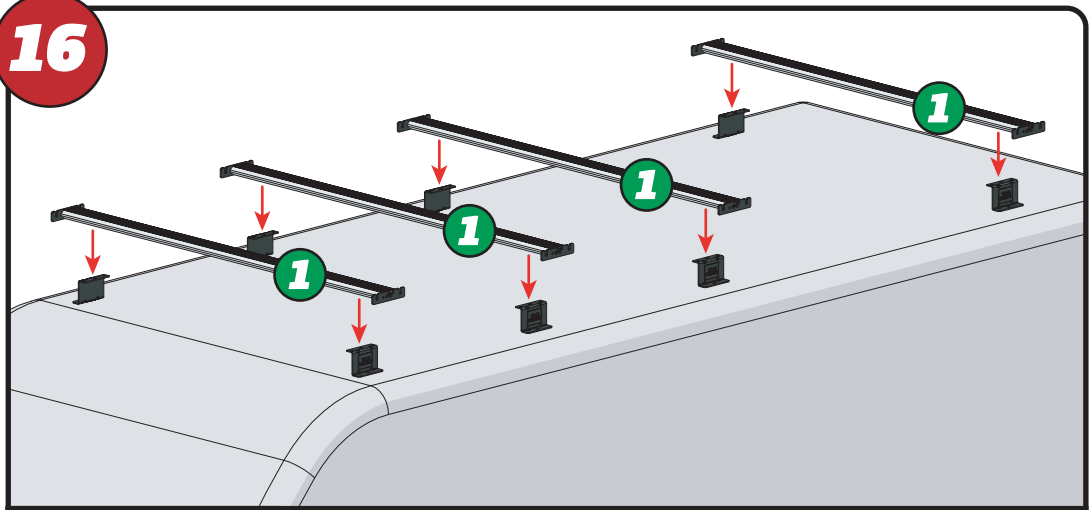

17

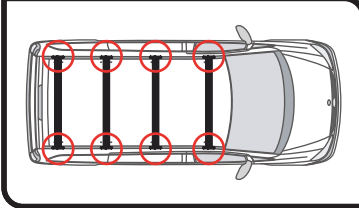
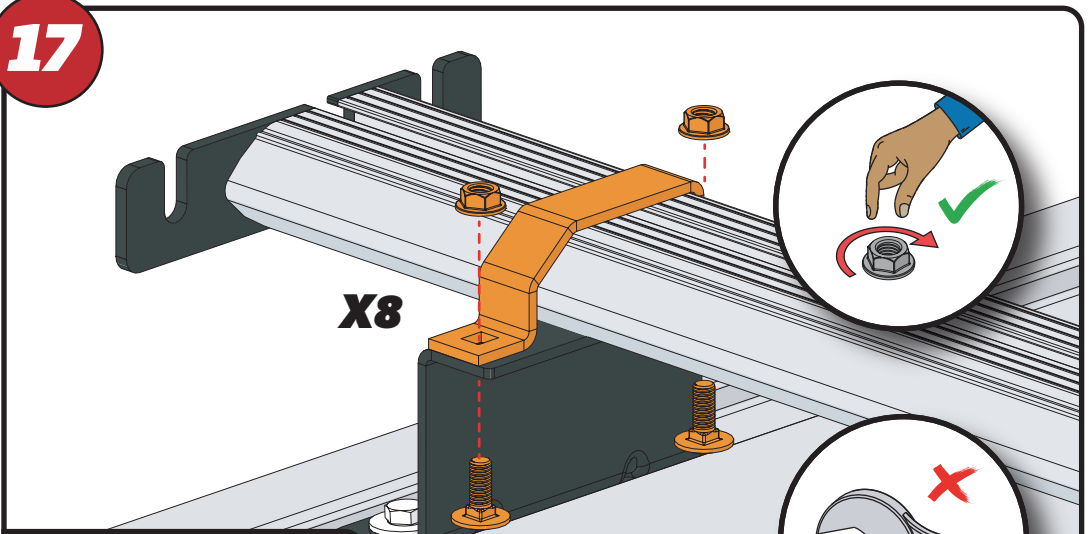

18

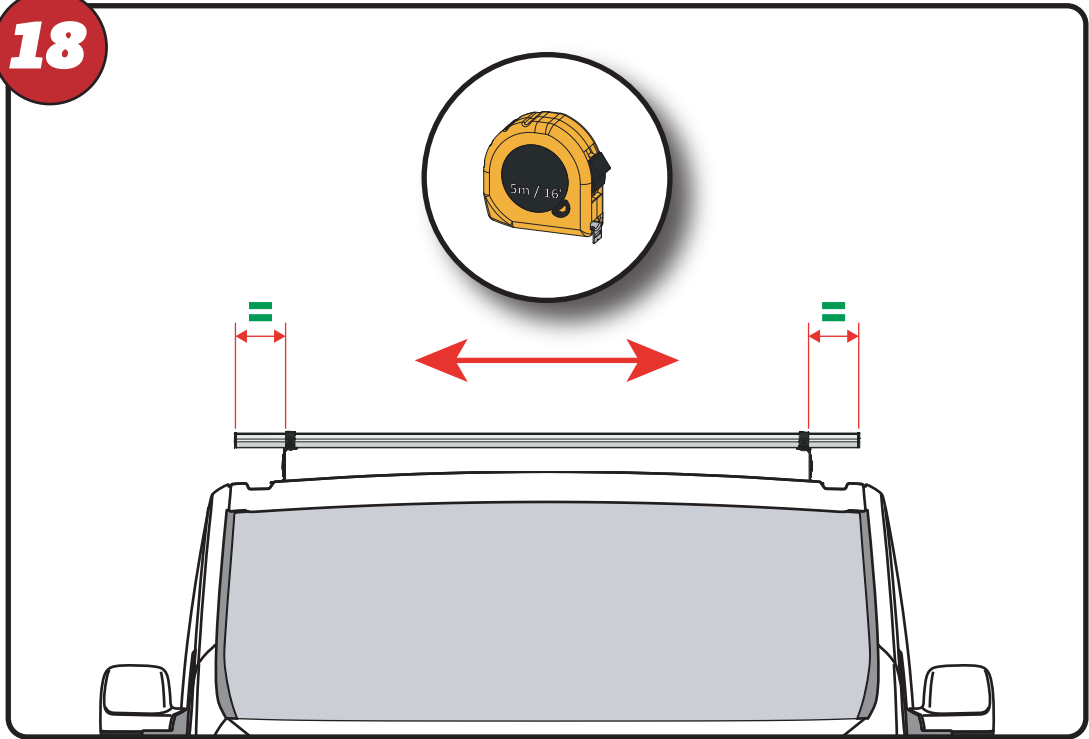

19

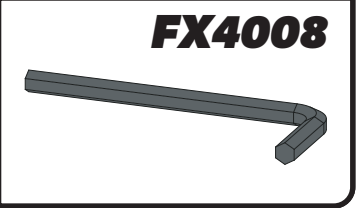
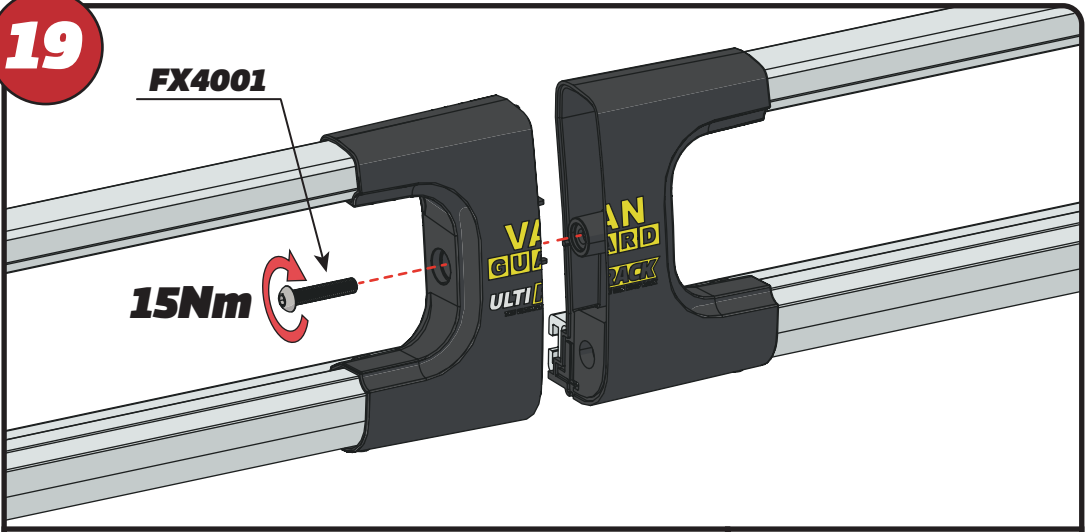

20

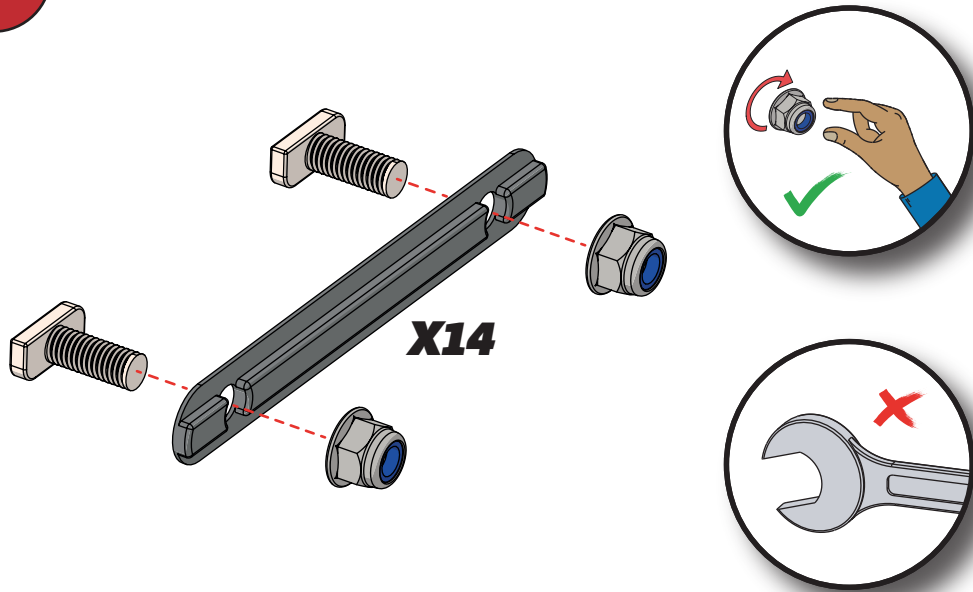

21

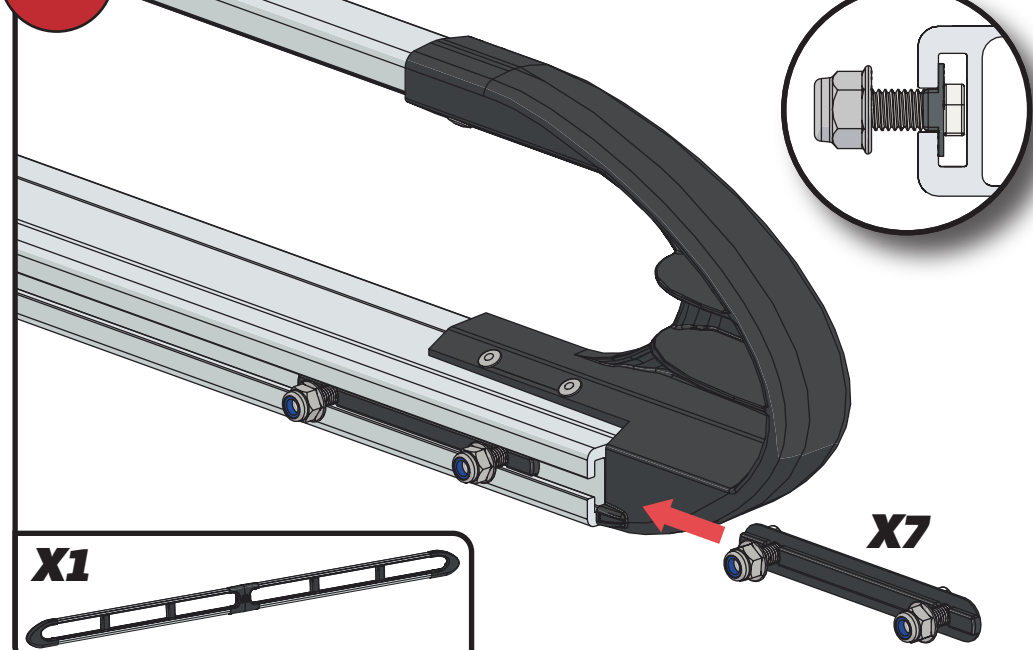

22

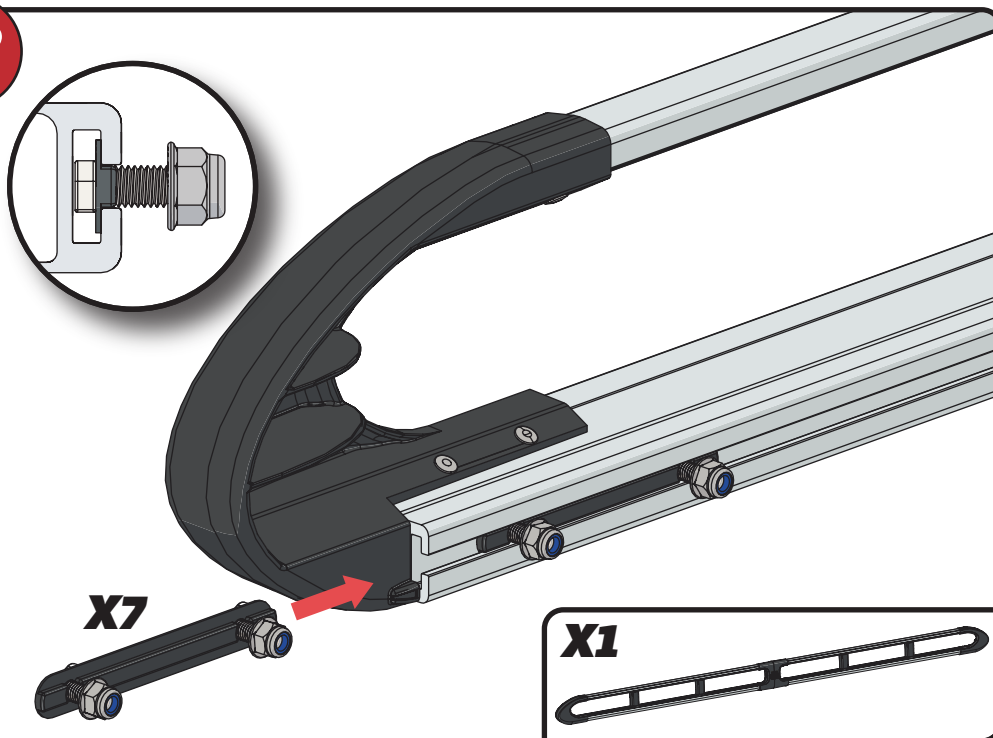

23

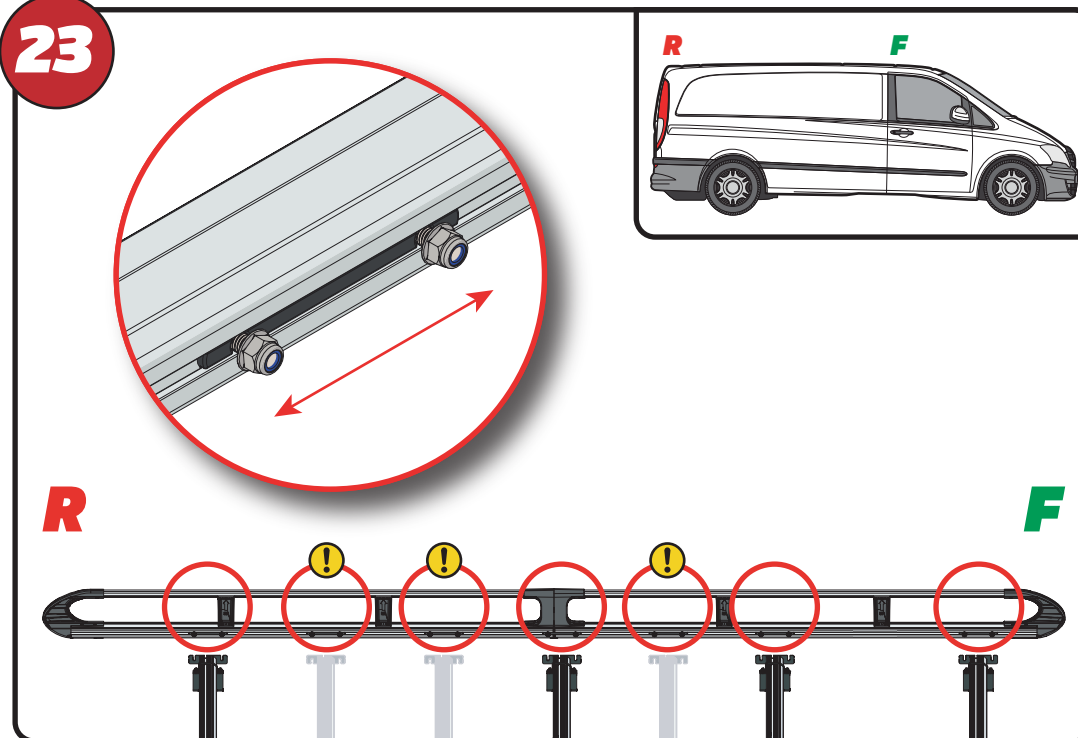

24

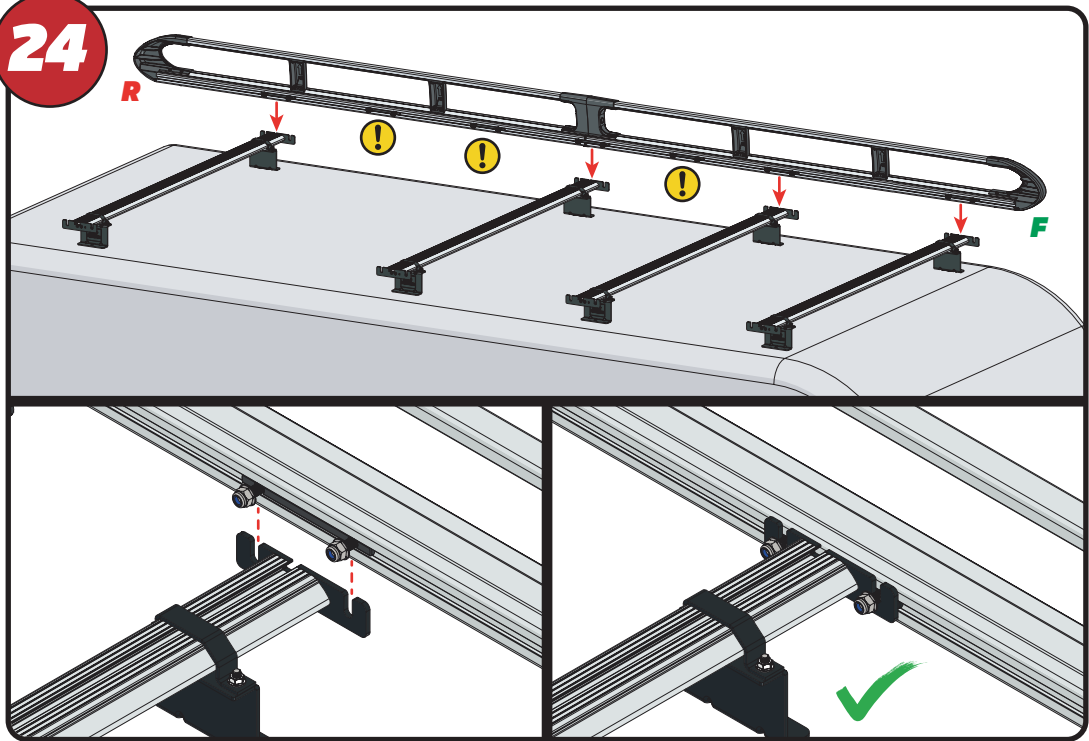

25

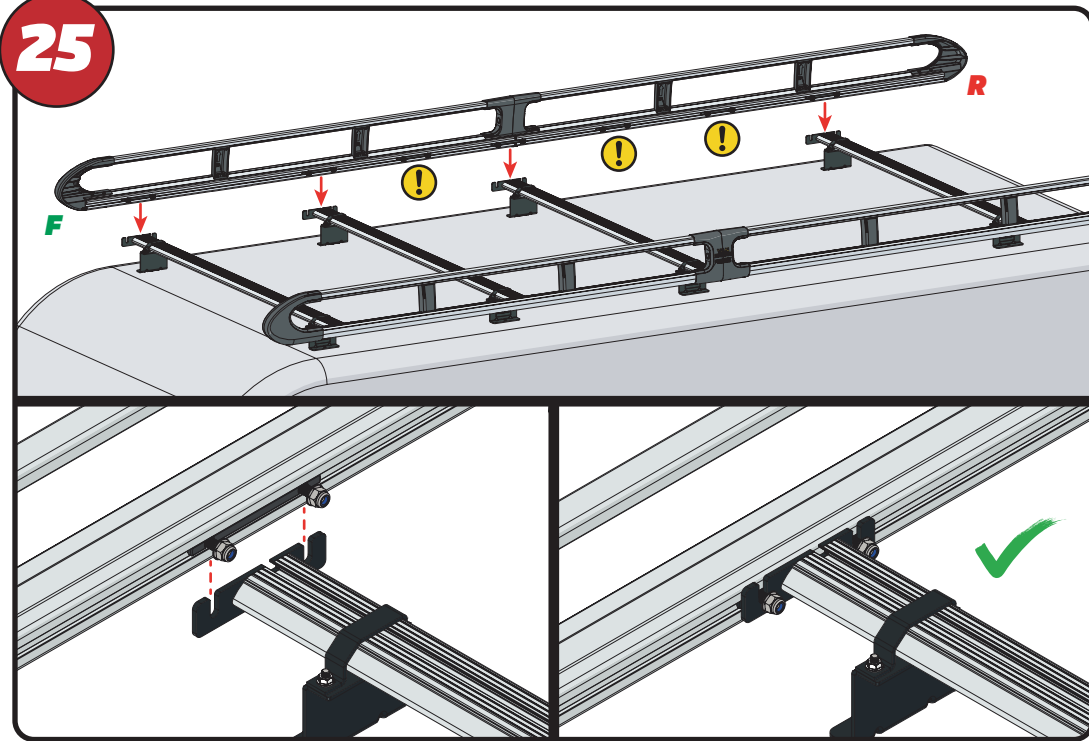

26

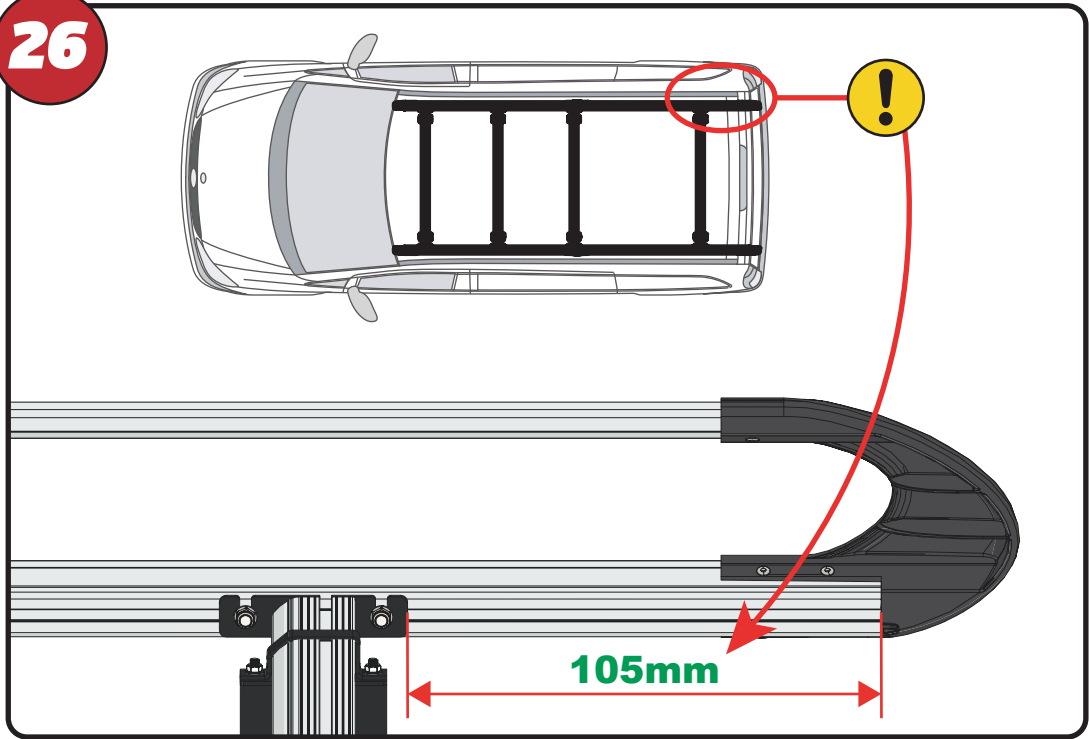

27

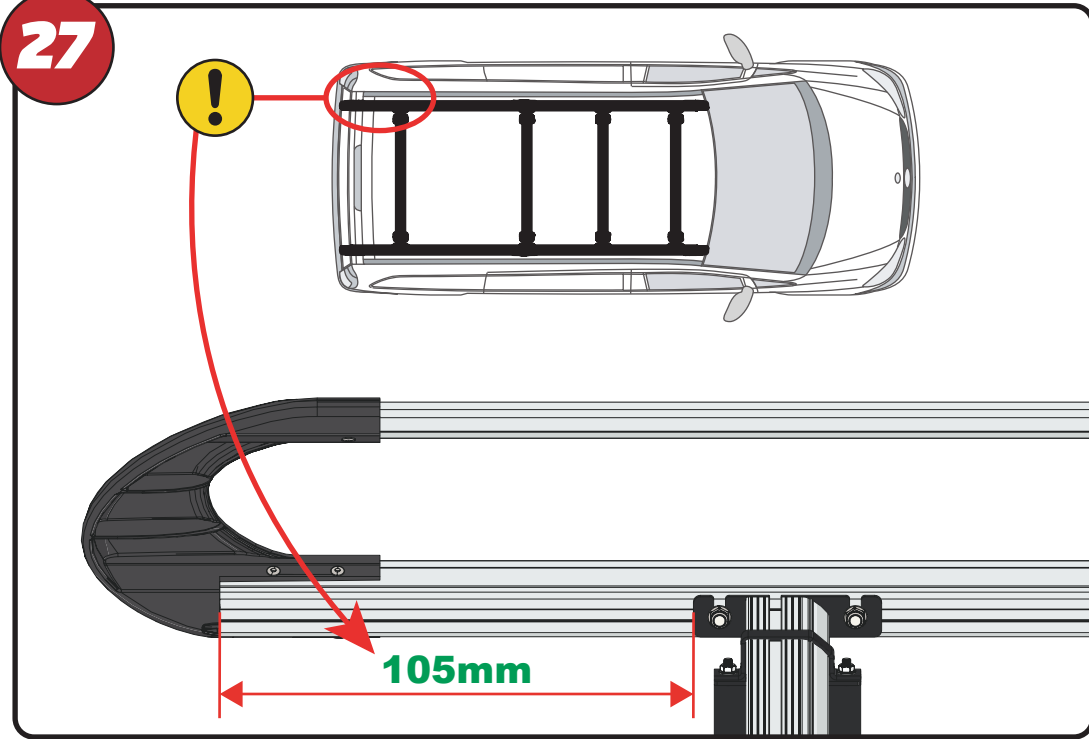

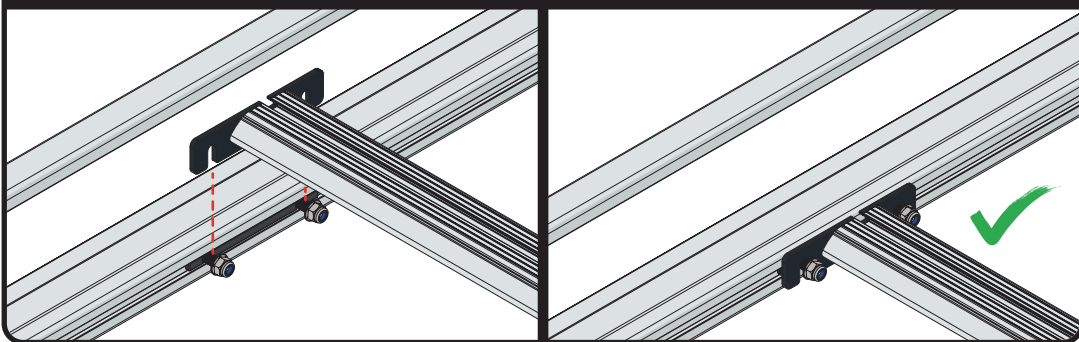
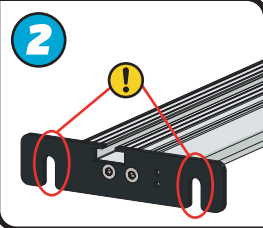
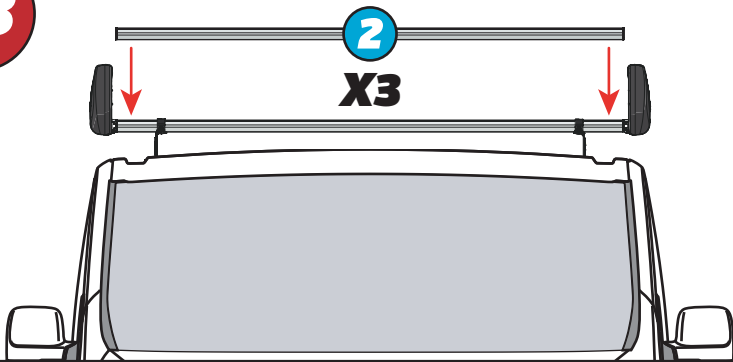
28**29**

XXX =
PAGE 2 OF 15

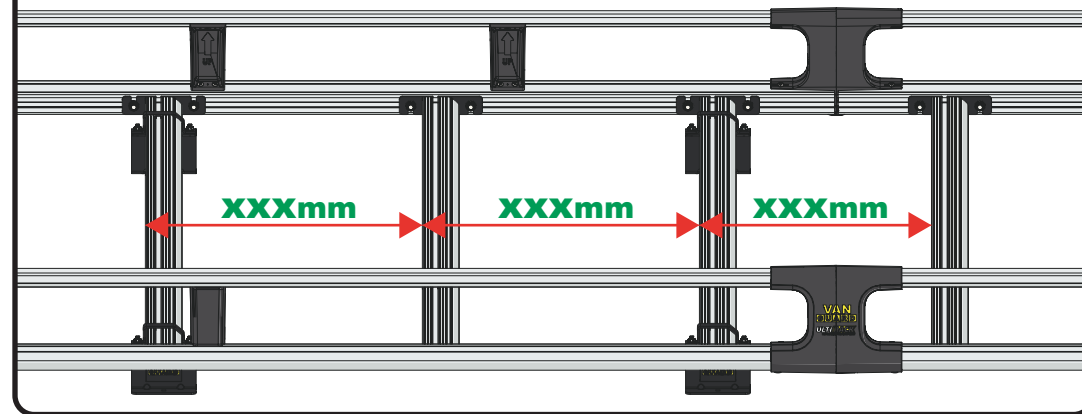
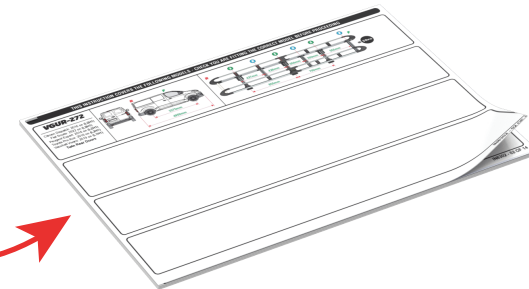
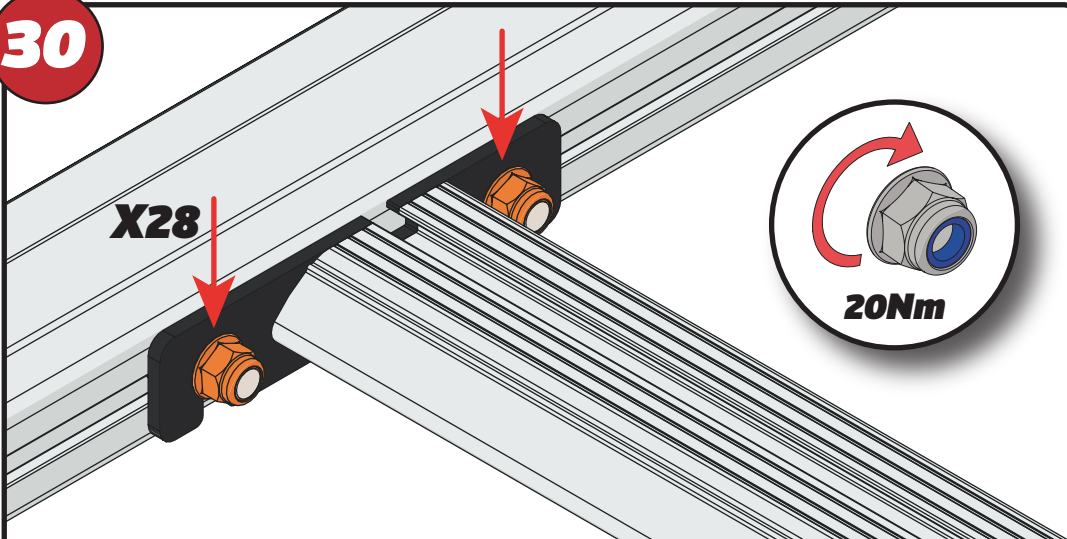
**30**

EN - TIGHTEN ALL OF THE CROSS BARS
 DE - ALLE QUERSTANGEN FESTZIEHEN
 FR - SERREZ TOUTES LES BARRES TRANSVERSALES
 NL - DRAAI ALLE DWARSBALK VAN HET DAK AAN
 ES - APRIETE TODAS LAS BARRAS TRANSVERSALES
 IT - STRINGERE TUTTE LE BARRE TRASVERSALI

SV - SKRU UPP ALLA KORSSTANGAR
 DA - SKRU ALLE TAGBØJLER OP
 NO - SKRU OPP ALLE TVERRSTENGER
 PL - DOKRĘCIĆ WSZYSTKIE POPRZECZKI
 CS - VŠECHNY PŘÍČNÉ TYČE SEŠROUJTE

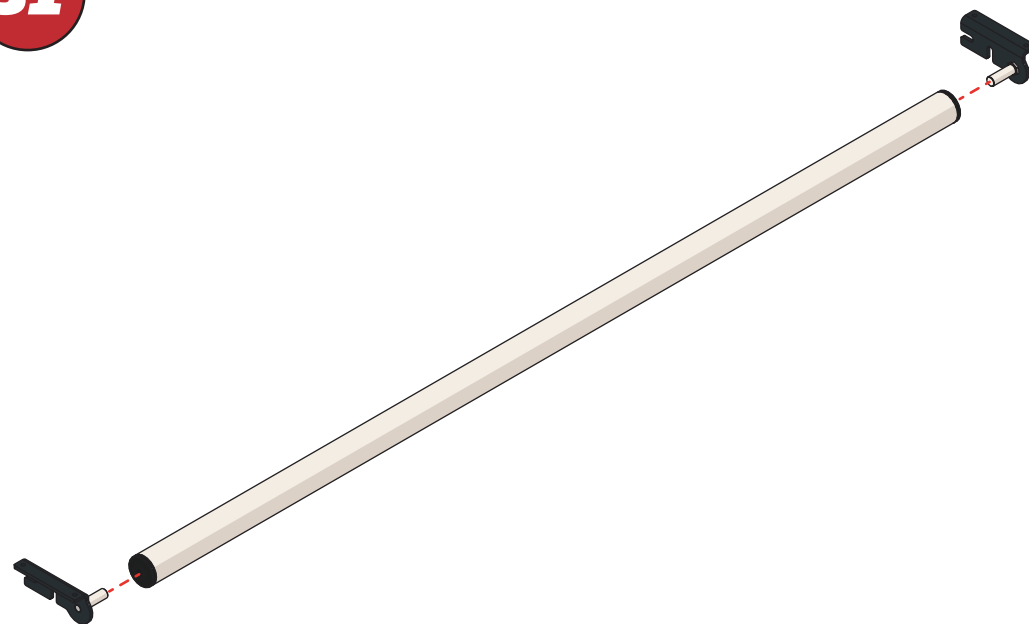
31

32

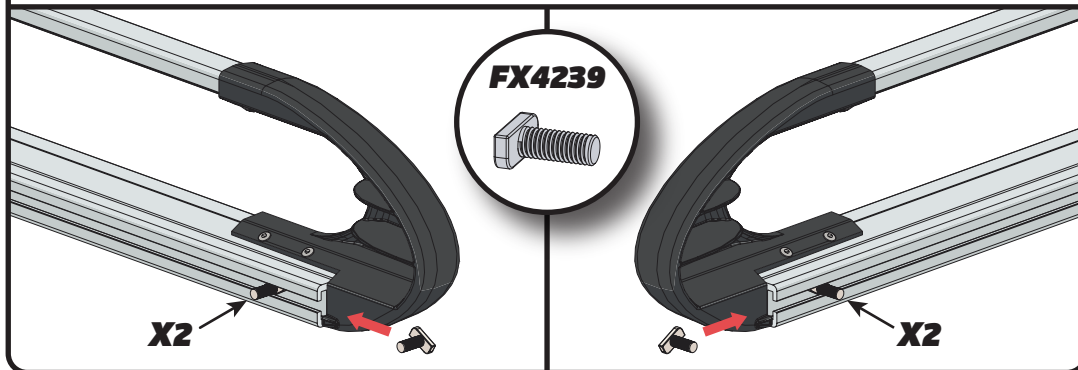
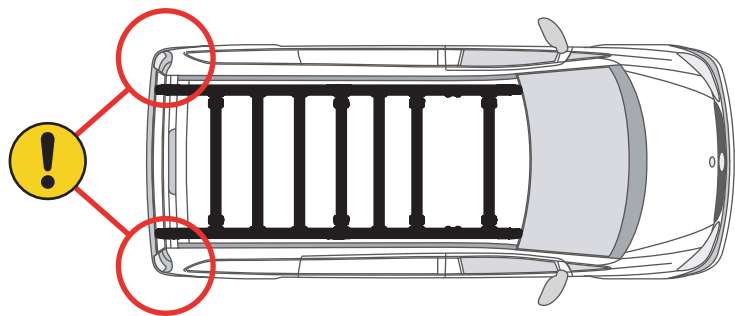

33

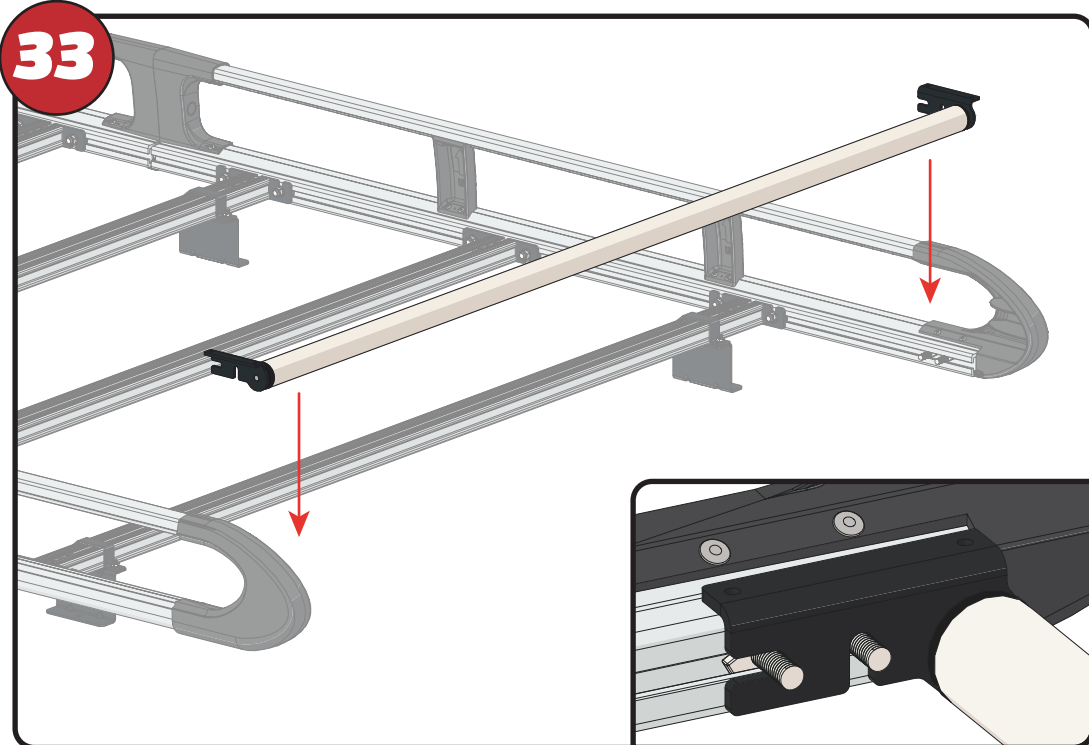

34

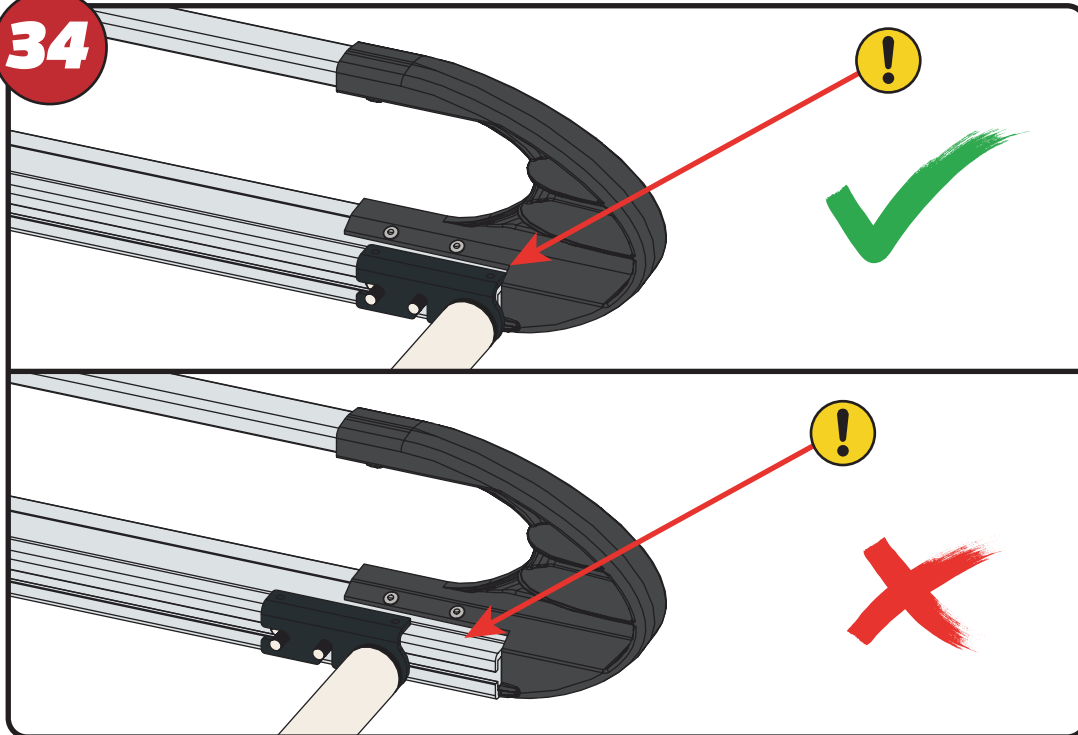

35

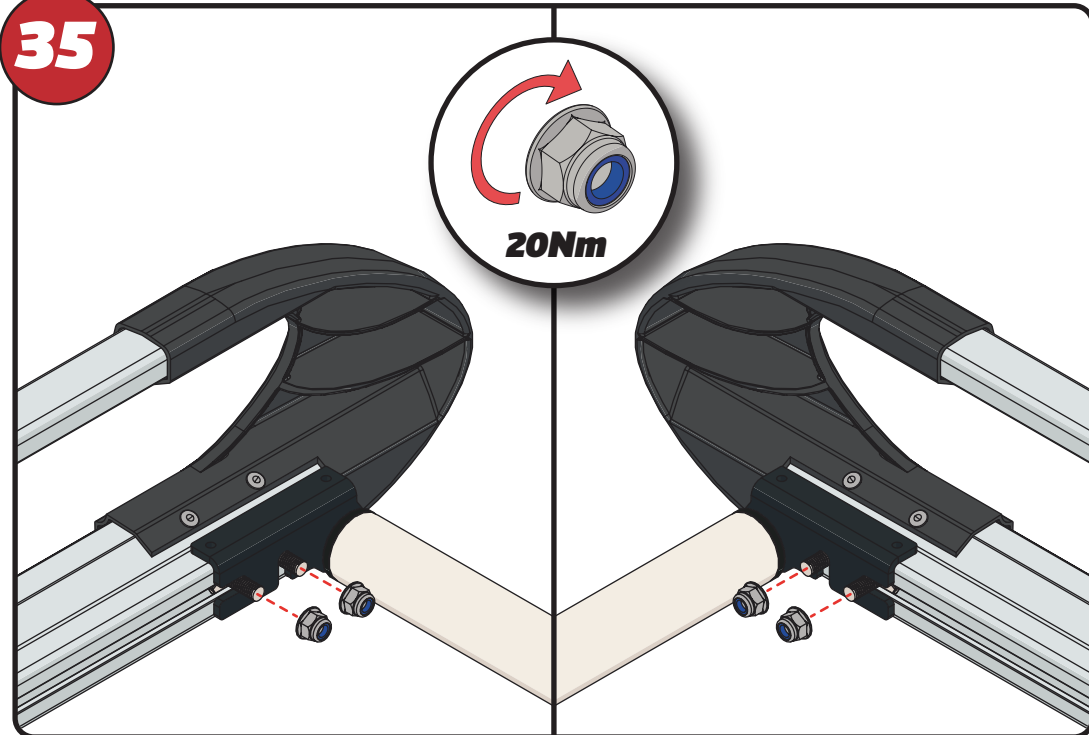

36

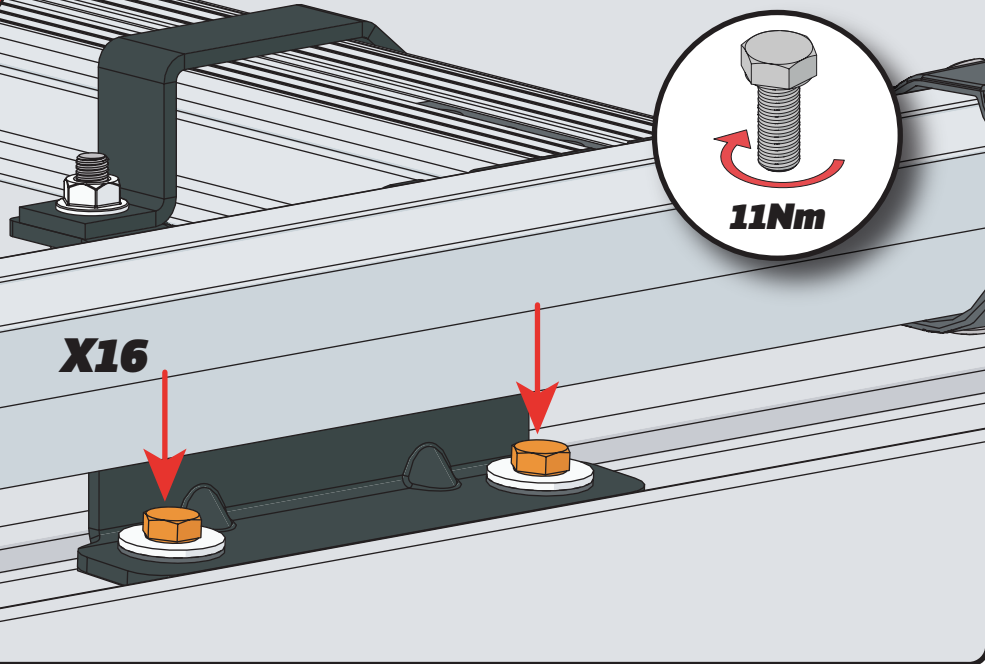

37

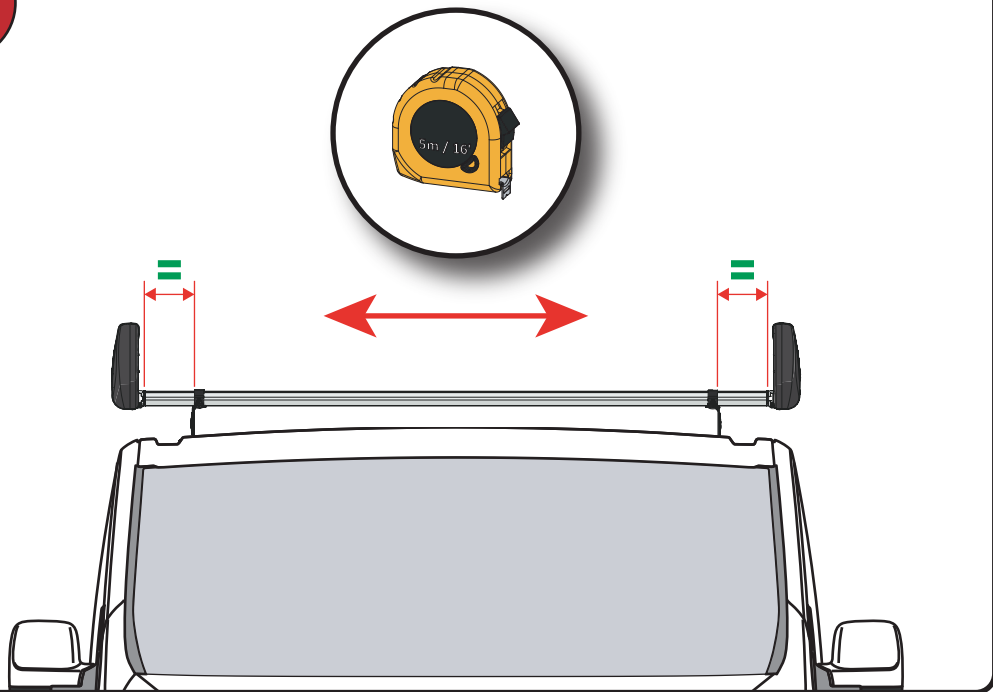

38

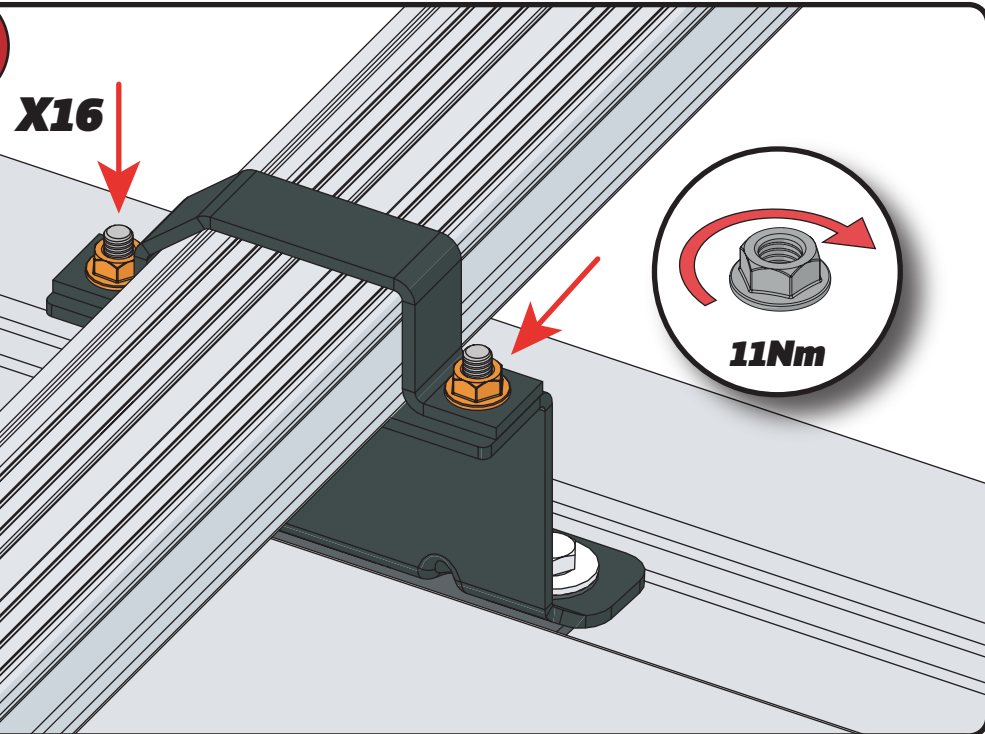

39

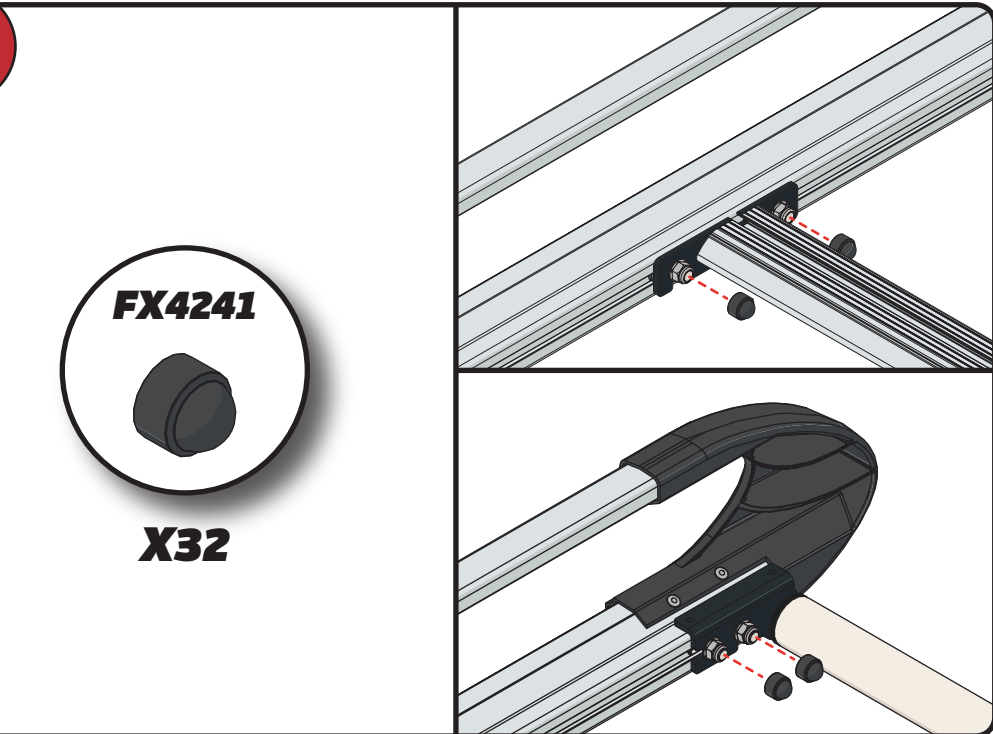

40

X8

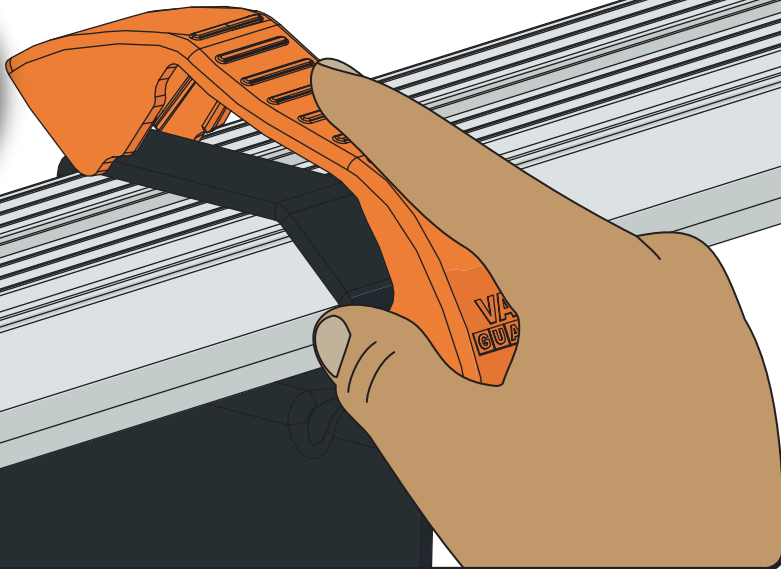

41

X4

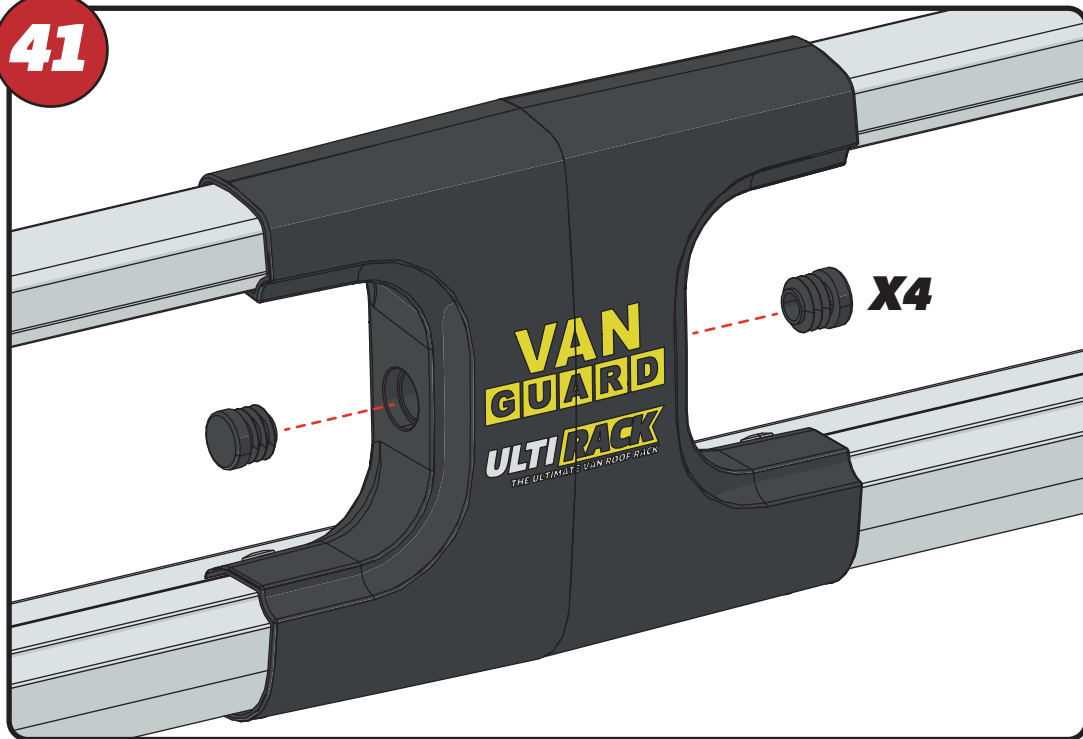

42

